



Lecture 3

RF Acceleration in Linacs

Part 1



Outline

- Transit-time factor
- Coupled RF cavities and normal modes
- Examples of RF cavity structures

- Material from
 - *Wiedemann, Chapters 15 and 6*
 - *Wangler, Chapters 2 and 3*



Transit Time Factor

- We now consider the energy gained by a charged particle that traverses an *accelerating gap*, such as a pillbox cavity in TM_{010} mode.
- The energy-gain is complicated by the fact that the RF field is changing while the particle is in the gap.



Transit Time Factor

- We will consider this problem by considering successively more realistic (and complicated) models for the accelerating gap, where in each case the field varies sinusoidally in time.
- We also must consider the possibility that the energy gain depends on particle radius.

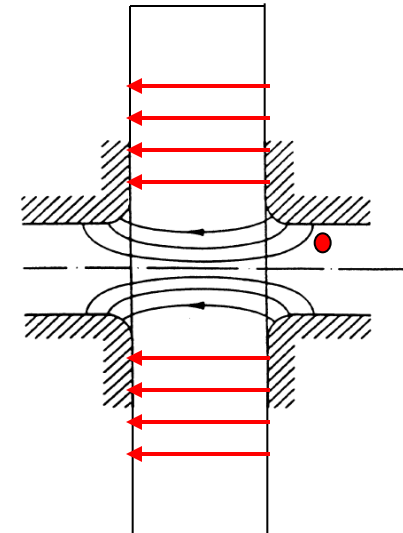
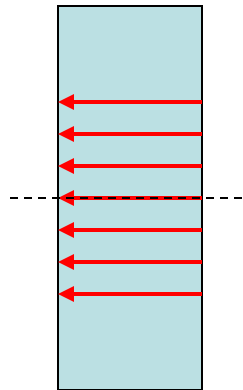
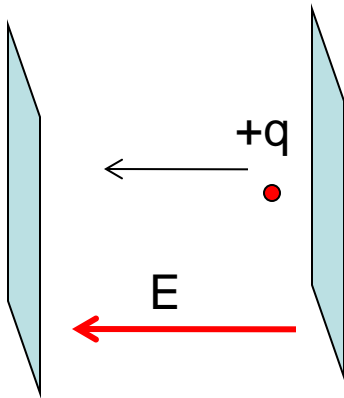



Acceleration by Time-Varying Fields

Consider infinite parallel plates separated by a distance L with sinusoidal voltage applied. Assume uniform E -field in gap (neglect holes)

$$E_z = E_z(t) = E_0 \cos(\omega t + \phi)$$

where at $t=0$, the particle is at the center of the gap ($z=0$), and the phase of the field relative to the crest is ϕ .
But t is a function of position $t=t(z)$, with

$$t(z) = \int_0^z \frac{dz}{v(z)}$$

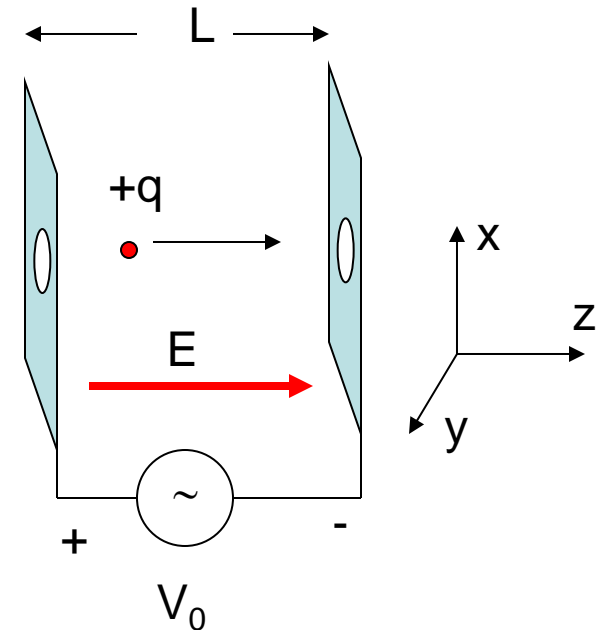

The energy gain in the *accelerating gap* is

$$\Delta W = q \int_{-L/2}^{L/2} E_z dz = q E_0 \int_{-L/2}^{L/2} \cos(\omega t(z) + \phi) dz$$



Energy Gain in an Accelerating Gap

- Assume the velocity change through the gap is small, so that $t(z) = z/v$, and

$$\omega t \approx \omega \frac{z}{v} = \frac{2\pi c}{\lambda} \frac{z}{c\beta} = \frac{2\pi z}{\beta\lambda}$$

$$\Delta W = qE_0 \int_{-L/2}^{L/2} (\cos \omega t \cos \phi - \sin \omega t \sin \phi) dz$$

This is an odd-function of z

$$\Delta W = qE_0 \cos \phi \int_{-L/2}^{L/2} \cos\left(\frac{2\pi z}{\beta\lambda}\right) dz - qE_0 \sin \phi \int_{-L/2}^{L/2} \sin\left(\frac{2\pi z}{\beta\lambda}\right) dz$$

$$\Delta W = qE_0 \cos \phi \frac{\beta\lambda}{2\pi} \left[\sin \frac{2\pi z}{\beta\lambda} \right]_{-L/2}^{L/2}$$



Energy Gain and Transit Time Factor

$$\Delta W = qE_0 \frac{\sin(\pi L / \beta\lambda)}{\pi L / \beta\lambda} L \cos \phi$$

$$\Delta W = qV_0 T \cos \phi$$

$$T = \frac{\sin(\pi L / \beta\lambda)}{\pi L / \beta\lambda}$$

- Compare to energy gain from static DC field:

$$\Delta W = \Delta W_{DC} T \cos \phi$$

- T is the *transit-time factor*: a factor that takes into account the time-variation of the field during particle transit through the gap.
- ϕ is the *synchronous phase*, measured from the crest.



Transit-Time Factor

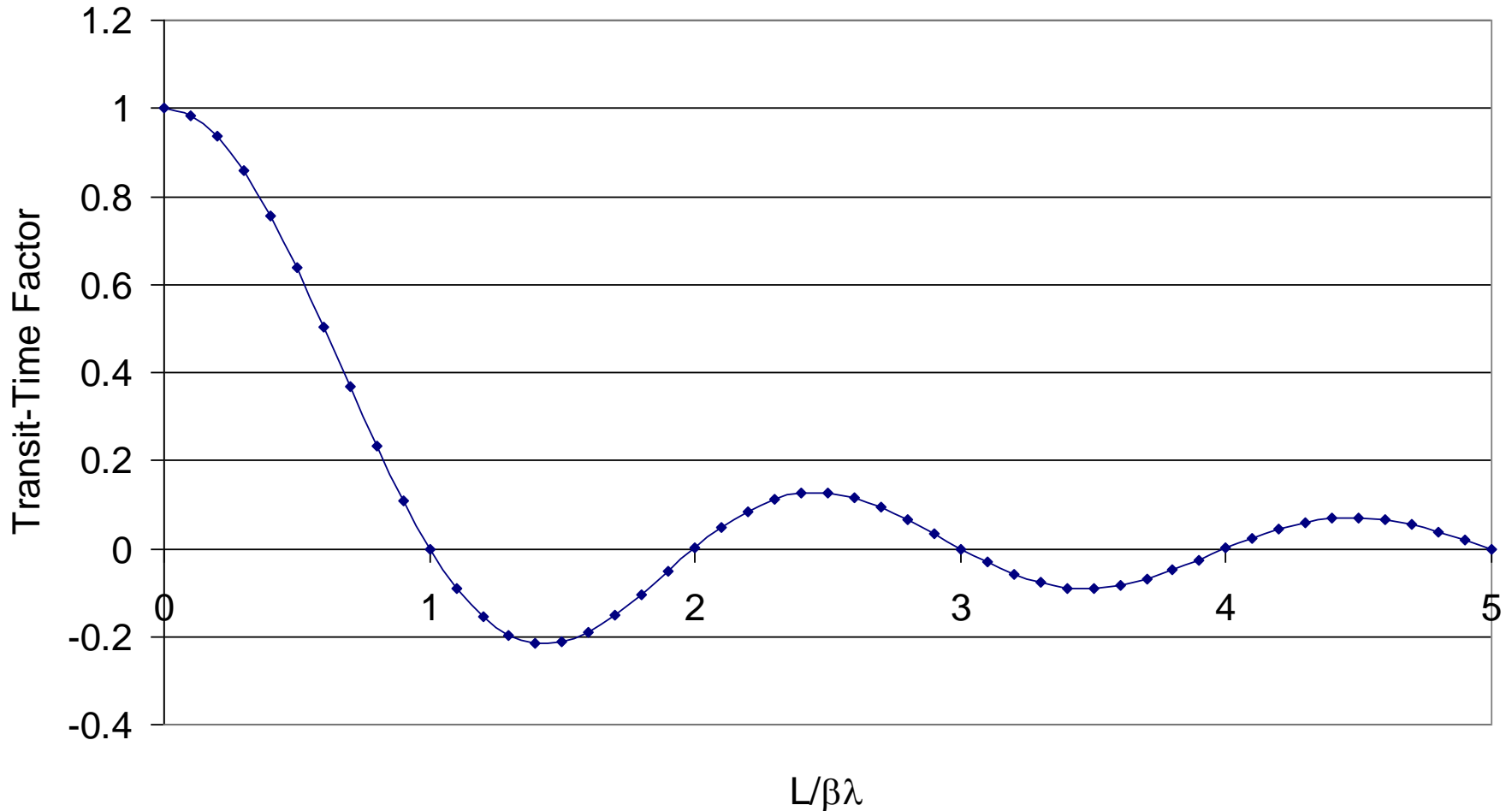

For efficient acceleration by RF fields, we need to properly match the gap length L to the distance that the particle travels in one RF wavelength, $\beta\lambda$.



Transit Time Factor for Real RF Gaps

- The energy gain just calculated for infinite planes is the same as that for an on-axis particle accelerated in a pillbox cavity neglecting the beam holes.
- A more realistic accelerating field depends on r, z

$$E_z = E_z(r, z, t) = E(r, z) \cos(\omega t + \phi)$$

- Calculate the energy gain as before:

$$\Delta W = q \int_{-L/2}^{L/2} E_z dz = q \int_{-L/2}^{L/2} E(0, z) \cos(\omega t(z) + \phi) dz$$

$$\Delta W = q \int_{-L/2}^{L/2} E(0, z) (\cos \omega t \cos \phi - \sin \omega t \sin \phi) dz$$

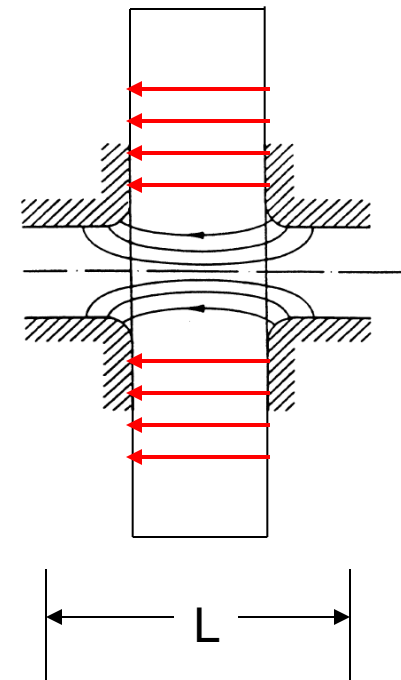
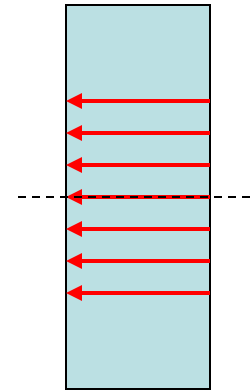



Transit-time Factor

- Choose the origin at the electrical center of the gap, defined as

$$\int_{-L/2}^{L/2} E(0, z) \sin \omega t(z) dz = 0$$

- This gives

$$\Delta W = qV_0 T \cos \phi = q \left[\int_{-L/2}^{L/2} E(0, z) dz \right] \left[\frac{\int_{-L/2}^{L/2} E(0, z) \cos \omega t dz}{\int_{-L/2}^{L/2} E(0, z) dz} \right] \cos \phi$$

- From which we identify the general form of the transit-time factor as

$$T = \frac{\int_{-L/2}^{L/2} E(0, z) \cos \omega t dz}{\int_{-L/2}^{L/2} E(0, z) dz}$$



Transit-time Factor

- Assuming that the velocity change is small in the gap, then

$$\omega t \approx \omega \frac{z}{v} = \frac{2\pi z}{\beta\lambda} = kz$$

- The transit time factor can be expressed as

$$T(k) \equiv T(0, k) = \frac{1}{V_0} \int_{-L/2}^{L/2} E(0, z) \cos(kz) dz$$
$$V_0 = \int_{-L/2}^{L/2} E(0, z) dz \quad k = \frac{2\pi}{\beta\lambda}$$



Radial Dependence of Transit-time Factor

- We calculated the Transit-time factor for an on-axis particle. We can extend this analysis to the transit-time factor and energy gain for off-axis particles.
- This is important because the electric-field in a pillbox cavity decreases with radius (remember TM_{010} fields):

$$T(r, k) = \frac{1}{V_0} \int_{-L/2}^{L/2} E(r, z) \cos(kz) dz$$

$$T(r, k) = T(k) I_0(Kr)$$

- Here I_0 is the *modified Bessel function of order zero*, and

$$K = \frac{2\pi}{\gamma\beta\lambda}$$

- Giving for the energy gain

$$\Delta W = qV_0 T(k) I_0(Kr) \cos \phi$$

which is the on-axis result modified by the r-dependent Bessel function.



Realistic Geometry of an RF Gap

- Assume accelerating field at drift-tube bore radius ($r=a$) is constant within the gap, and zero outside the gap within the drift tube walls

$$E(r = a, z) = \begin{cases} E_g & 0 \leq |z| \leq g/2 \\ 0 & g/2 \leq |z| \end{cases}$$

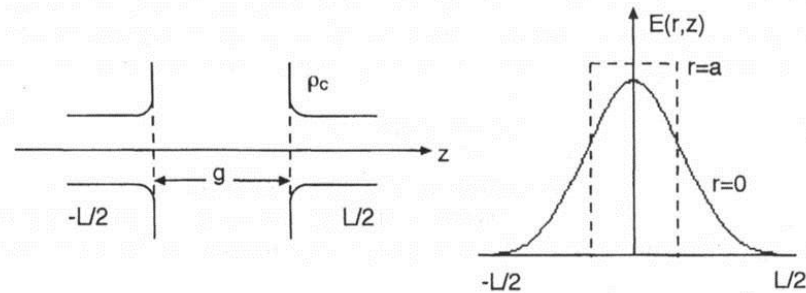

Figure 2.1 Gap geometry and field distribution.

- Using the definition of transit-time factor:

$$T(r, k) = \frac{1}{V_0} \int_{-L/2}^{L/2} E(r, z) \cos(kz) dz$$

- we get

$$V_0 T(k) = \frac{E_g g}{I_0(Ka)} \frac{\sin(kg/2)}{kg/2} \quad V_0 = \frac{E_g g}{J_0(2\pi a / \lambda)}$$

- Finally,

$$T(r, k) = T(k) I_0(Kr) = I_0(Kr) \frac{J_0(2\pi a / \lambda)}{I_0(Ka)} \frac{\sin(\pi g / \beta \lambda)}{\pi g / \beta \lambda}$$



What about the drift tubes?

- The cutoff frequency for a cylindrical waveguide is

$$\omega_c = 2.405c / R$$

- The drift tube has a cutoff frequency, below which EM waves do not propagate.
- The propagation factor k is

$$k_z^2 = \left(\frac{2.405}{R_c} \right)^2 - \left(\frac{2.405}{R_{hole}} \right)^2 < 0$$

- So the electric field decays exponentially with penetration distance in the drift tube:

$$E_z = E_0 e^{i(kz - \omega t)} = E_0 e^{i(i|k|z - \omega t)} = E_0 e^{-|k|z} e^{-i\omega t}$$

- Example: 1 GHz cavity with $r=1$ cm beam holes:



Power and Acceleration Figures of Merit

- Quality Factor:
 - “goodness” of an oscillator
- Shunt Impedance:
 - “Ohms law” resistance
- Effective Shunt Impedance:
 - Impedance including TTF
- Shunt Impedance per unit length:
- Effective Shunt Impedance/unit length:
- “R over Q”:
 - Efficiency of acceleration per unit of stored energy

$$Q = \frac{\omega U}{P}$$

$$r_s = \frac{V_0^2}{P}$$

$$r = \frac{(V_0 T)^2}{P} = r_s T^2$$

$$Z = \frac{r_s}{L} = \frac{E_0^2}{P/L}$$

$$ZT^2 = \frac{r}{L} = \frac{(E_0 T)^2}{P/L}$$

$$\frac{r}{Q} = \frac{(V_0 T)^2}{\omega U}$$



Power Balance

- Power delivered to the beam is:

$$P_B = \frac{I\Delta W}{q}$$

- Total power delivered by the RF power source is:

$$P_T = P + P_B$$



Coupled RF Cavities and Normal Modes



Now, let's make a real linac

- We can accelerate particles in a pillbox cavity
- Real linacs are made by stringing together a series of pillbox cavities.
- These cavity arrays can be constructed from independently powered cavities, or by “coupling” a number of cavities in a single RF structure.



Coupling of two cavities

- Suppose we couple two RF cavities together:
- Each is an electrical oscillator with the same resonant frequency
- A beampipe couples the two cavities

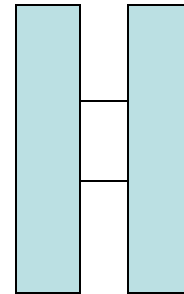

- Remember the case of mechanical coupling of two oscillators:
- Two mechanical modes are possible:
 - The “zero-mode”: $\phi_A - \phi_B = 0$, where each oscillates at natural frequency
 - The “pi-mode”: $\phi_A - \phi_B = \pi$, where each oscillates at a higher frequency

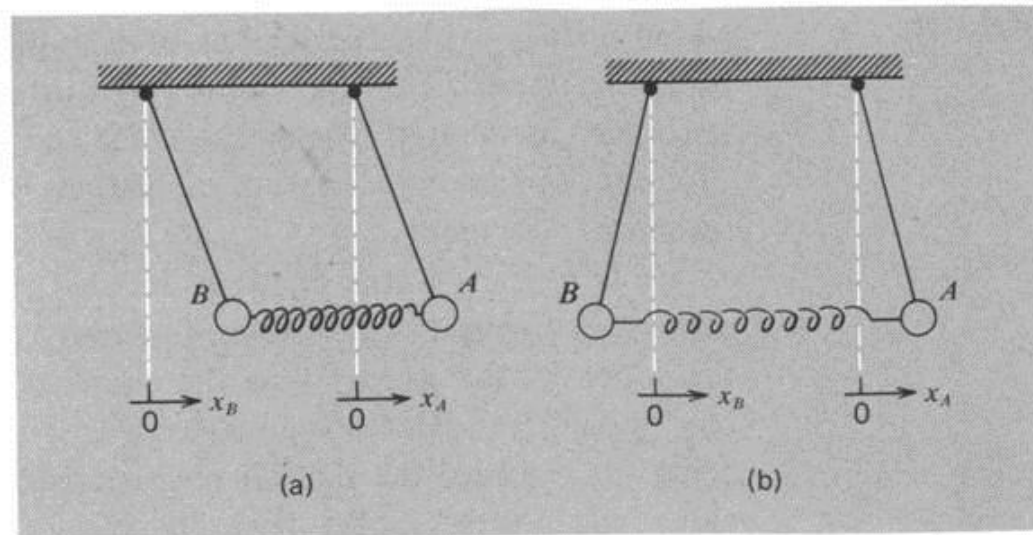

Fig. 5-4 (a) Lower normal mode of two coupled pendulums. (b) Higher normal mode of two coupled pendulums.



Coupling of electrical oscillators

- Two coupled oscillators, each with same resonant frequency:
- Apply Kirchoff's laws to each circuit:

$$\omega_0^2 = \frac{1}{LC}$$

$$\sum V = i_1(j\Omega L) + i_1 \frac{1}{j\Omega C} + i_2(j\Omega M) = 0$$

- Gives

$$i_1 \left(1 - \frac{\omega_0^2}{\Omega^2}\right) + i_2 \frac{M}{L} = 0$$

$$i_2 \left(1 - \frac{\omega_0^2}{\Omega^2}\right) + i_1 \frac{M}{L} = 0$$

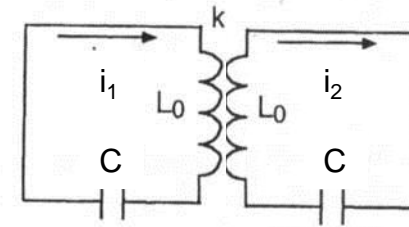

Figure 4.1 Oscillators.

- Which can be expressed as:

$$\begin{pmatrix} 1/\omega_0^2 & k/\omega_0^2 \\ k/\omega_0^2 & 1/\omega_0^2 \end{pmatrix} \begin{pmatrix} i_1 \\ i_2 \end{pmatrix} = \frac{1}{\Omega^2} \begin{pmatrix} i_1 \\ i_2 \end{pmatrix} \quad k = M/L$$

- You may recognize this as an eigenvalue problem

$$\tilde{M}\vec{X}_q = \frac{1}{\Omega_q^2} \vec{X}_q$$



Coupling of electrical oscillators

- There are two normal-mode eigenvectors and associated eigenfrequencies
- Zero-mode:

$$X_0 = \begin{pmatrix} 1 \\ 1 \end{pmatrix} \quad \Omega_0 = \frac{\omega_0}{\sqrt{1+k}}$$

- Pi-mode:

$$X_\pi = \begin{pmatrix} 1 \\ -1 \end{pmatrix} \quad \Omega_\pi = \frac{\omega_0}{\sqrt{1-k}}$$

- Like the coupled pendula, we have 2 normal modes, one for in-phase oscillation (“Zero-mode”) and another for out of phase oscillation (“Pi-mode”).
- It is important to remember that both oscillators have resonant frequencies Ω , different from the natural (uncoupled) frequency.



Normal modes for many coupled cavities

- $N+1$ coupled oscillators have $N+1$ normal-modes of oscillation.
- Normal mode spectrum:

$$\Omega_q = \frac{\omega_0}{\sqrt{1 + k \cos(\pi q / N)}}$$

where $q=0,1,\dots,N$ is the mode number.

- Not all are useful for particle acceleration.
- Standing wave structures of coupled cavities are all driven so that the beam sees either the zero or π mode.

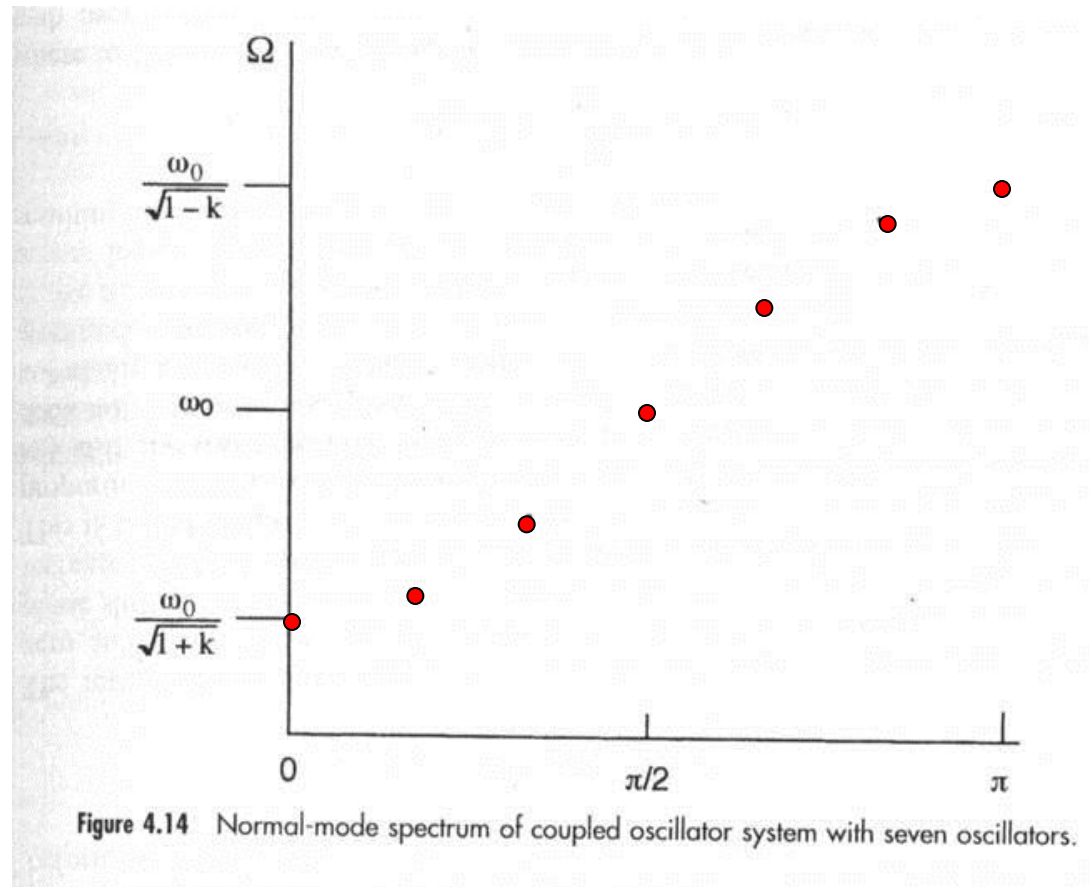



Example for a 3-cell Cavity: Zero-mode Excitation

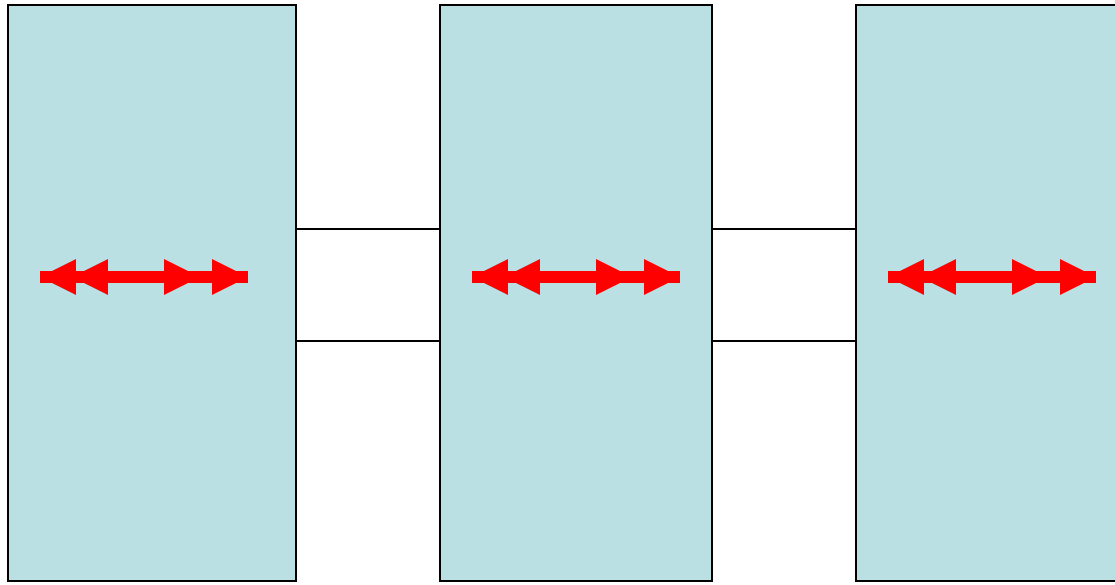

$\omega t = 0$

$\omega t = \pi/4$

$\omega t = \pi/2$

$\omega t = 3\pi/4$

$\omega t = \pi$

$\omega t = 5\pi/4$

$\omega t = 3\pi/2$

$\omega t = 7\pi/4$

$\omega t = 2\pi$



Example for a 3-cell Cavity: Pi-mode Excitation

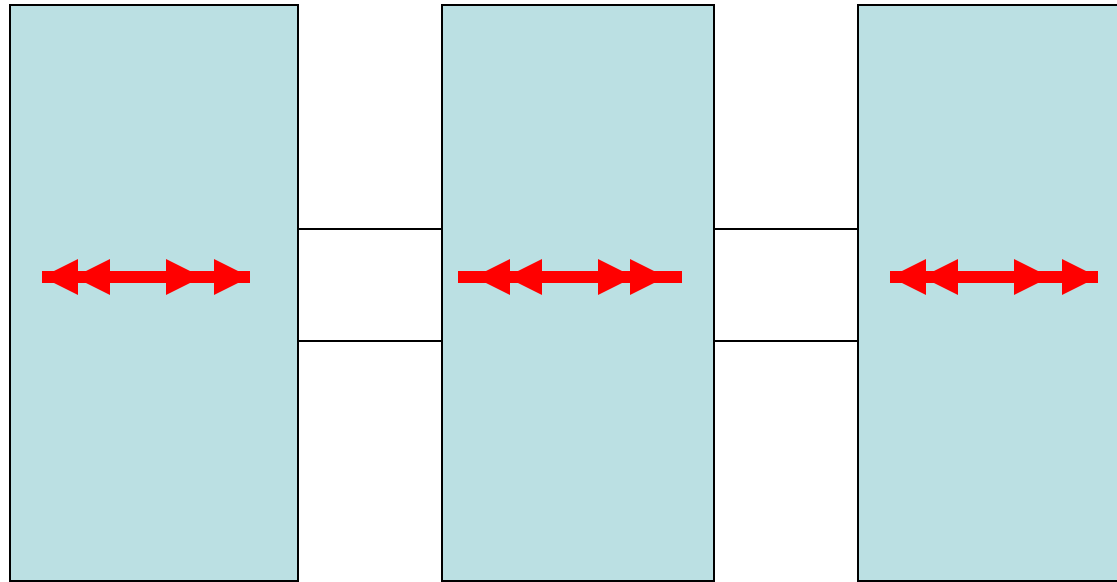

$\omega t = 0$

$\omega t = \pi/4$

$\omega t = \pi/2$

$\omega t = 3\pi/4$

$\omega t = \pi$

$\omega t = 5\pi/4$

$\omega t = 3\pi/2$

$\omega t = 7\pi/4$

$\omega t = 2\pi$



Synchronicity condition in multicell RF structures

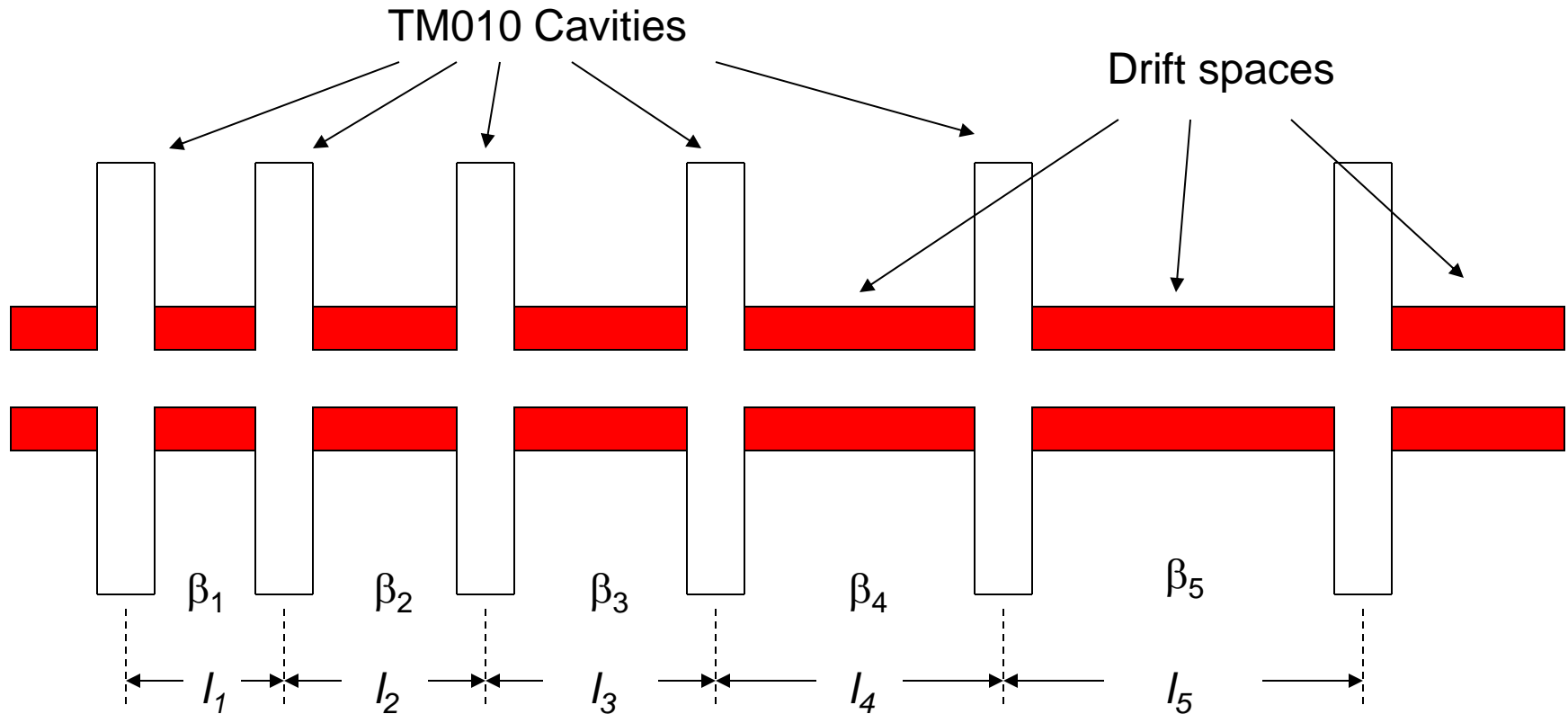

- Suppose we want a particle to arrive at the center of each gap at $\phi=0$. Then we would have to space the cavities so that the RF phase advanced by
 - 2π if the coupled cavity array was driven in zero-mode,
 - Or by π if the coupled cavity array was driven in pi-mode.



Synchronicity Condition

Zero-mode:

$$\phi = \omega t = \frac{2\pi c}{\lambda} t = \frac{2\pi c}{\lambda} \frac{l_n}{c\beta_n} = 2\pi$$

$$l_n = \beta_n \lambda$$

- RF gaps (cells) are spaced by $\beta\lambda$, which increases as the particle velocity increases.

Pi-mode:

$$\phi = \omega t = \frac{2\pi c}{\lambda} t = \frac{2\pi c}{\lambda} \frac{l_n}{c\beta_n} = \pi$$

$$l_n = \beta_n \lambda / 2$$

- RF gaps (cells) are spaced by $\beta\lambda/2$, which increases as the particle velocity increases.



Energy Gain in Multicell Superconducting Pi-Mode Cavity

- Elliptical multicell cavity in pi-mode:

$$E(r=0, z) = E_g \cos k_s z$$

where $k_s = \pi/L$, and $L = \beta_s \lambda / 2$.

- This gives, for a particle with velocity matching the “geometric-beta” of the cavity:

$$T(k_s) = T(0, k_s) = \frac{E_g}{V_0} \int_{-L/2}^{L/2} \cos^2(k_s z) dz = \frac{\pi}{4}$$

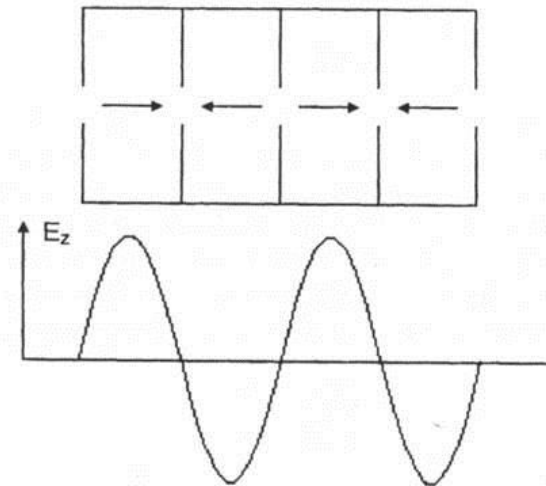
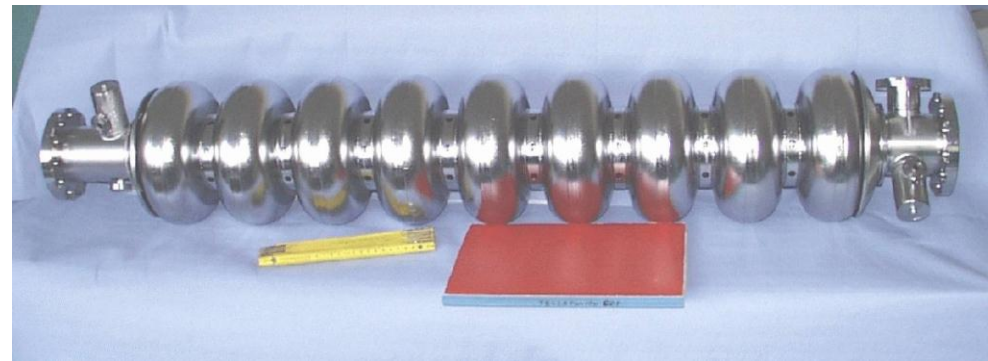

Figure 2.3 Axial electric-field distribution showing the effect of the π -mode boundary conditions, which causes the field to cross the axis at the boundaries of each cell.



Superconducting RF cavity for ILC



Examples of RF Cavity Structures



Alvarez Drift Tube Linac

- DTL consists of a long “tank” excited in TM_{010} mode (radius determines frequency).
- Drift tubes are placed along the beam-axis so that the accelerating gaps satisfy synchronicity condition, with nominal spacing of $\beta\lambda$.
- The cutoff frequency for EM propagation within the drift tubes is much greater than the resonant frequency of the tank ($\omega_c = 2.405c/R$).
- Each tube (cell) can be considered a separate cavity, so that the entire DTL structure is a set of coupled cavity resonators excited in the zero-mode.

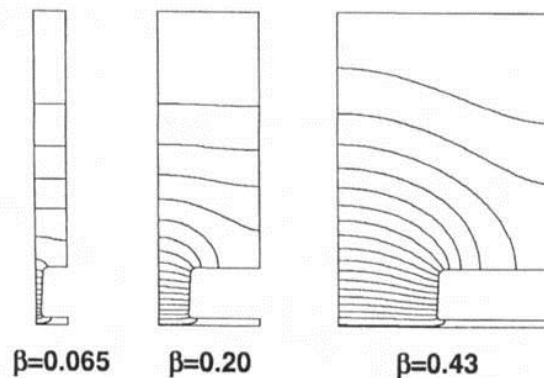
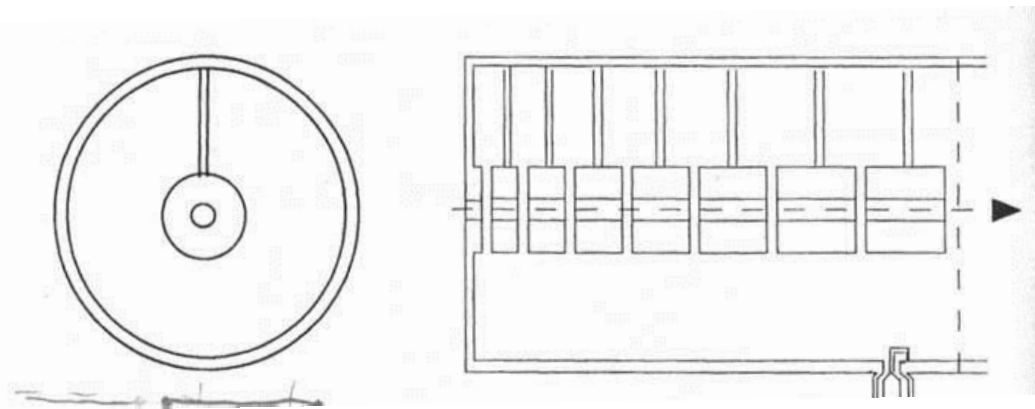
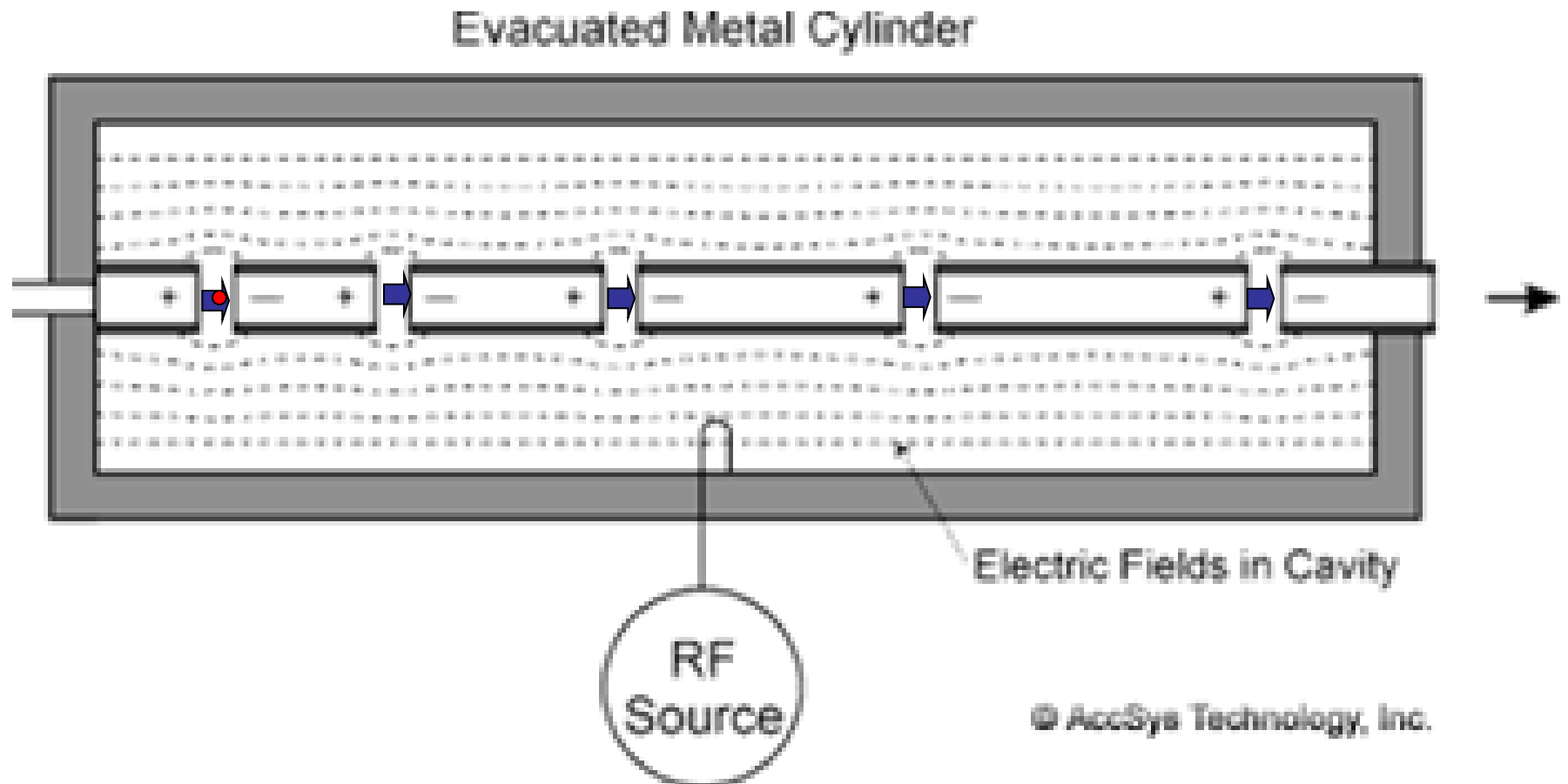

Figure 4.9 Electric-field lines shown in one quarter of the projections of three DTL cells as calculated by the program SUPERFISH (courtesy of J. H. Billen).



Zero-mode excitation of a Drift Tube Linac Tank

- $\phi = \omega t = 0, E_z = E_0$





Zero-mode excitation of a Drift Tube Linac Tank

- $\phi = \omega t = \pi/2, E_z = 0$

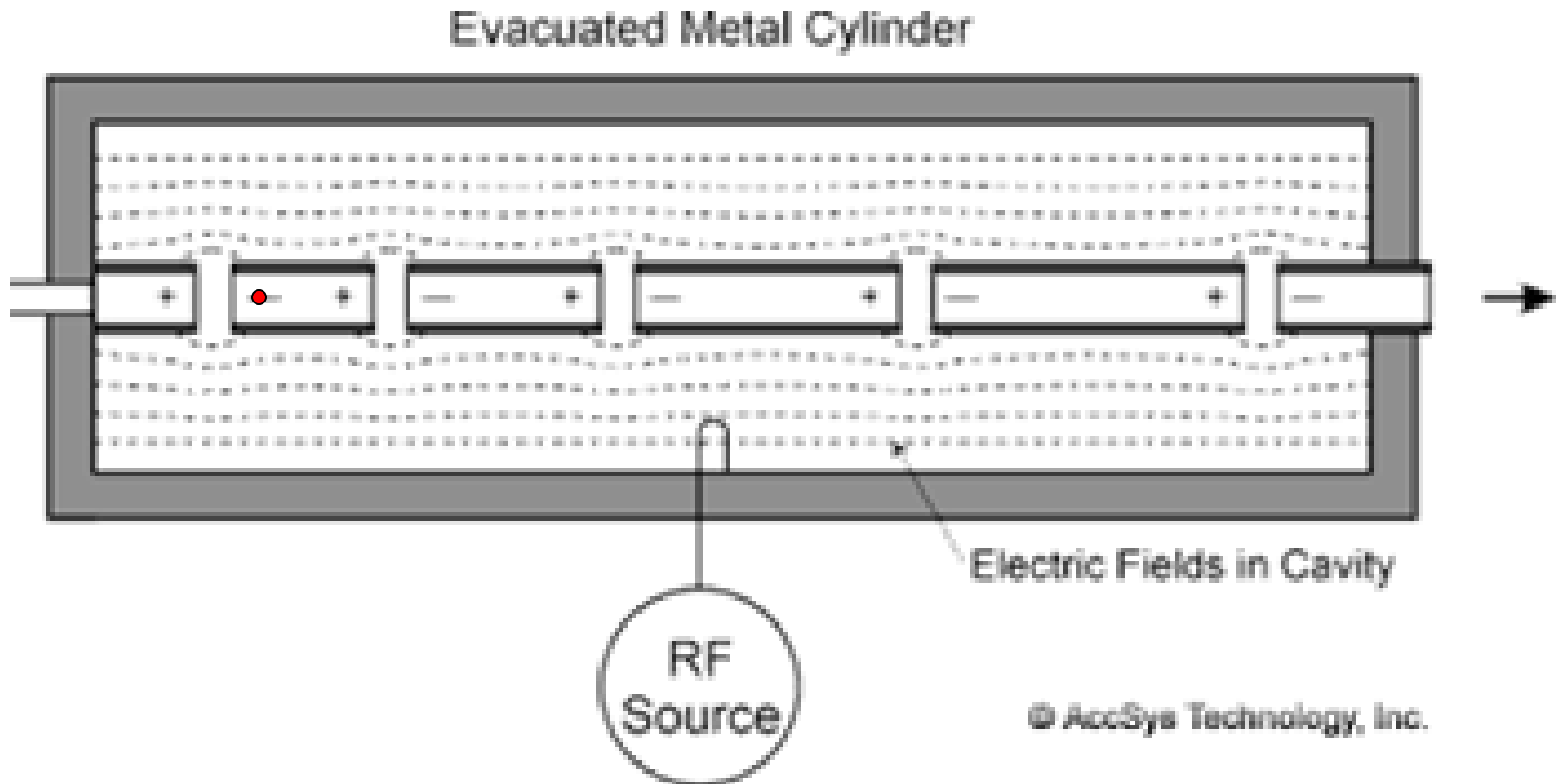



Zero-mode excitation of a Drift Tube Linac Tank

- $\phi = \omega t = \pi$, $E_z = -E_0$

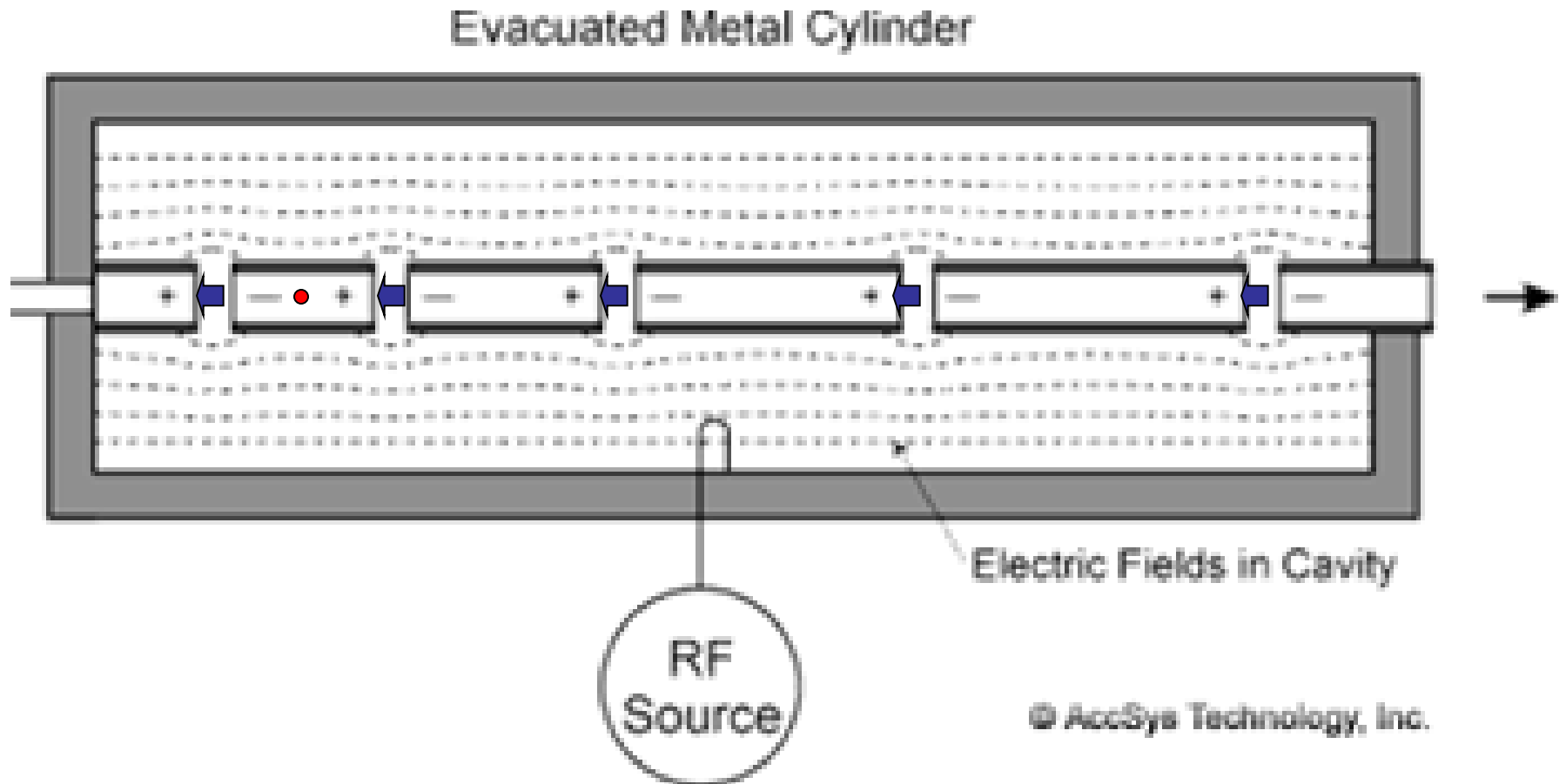



Zero-mode excitation of a Drift Tube Linac Tank

- $\phi = \omega t = 3\pi/2, E_z = 0$

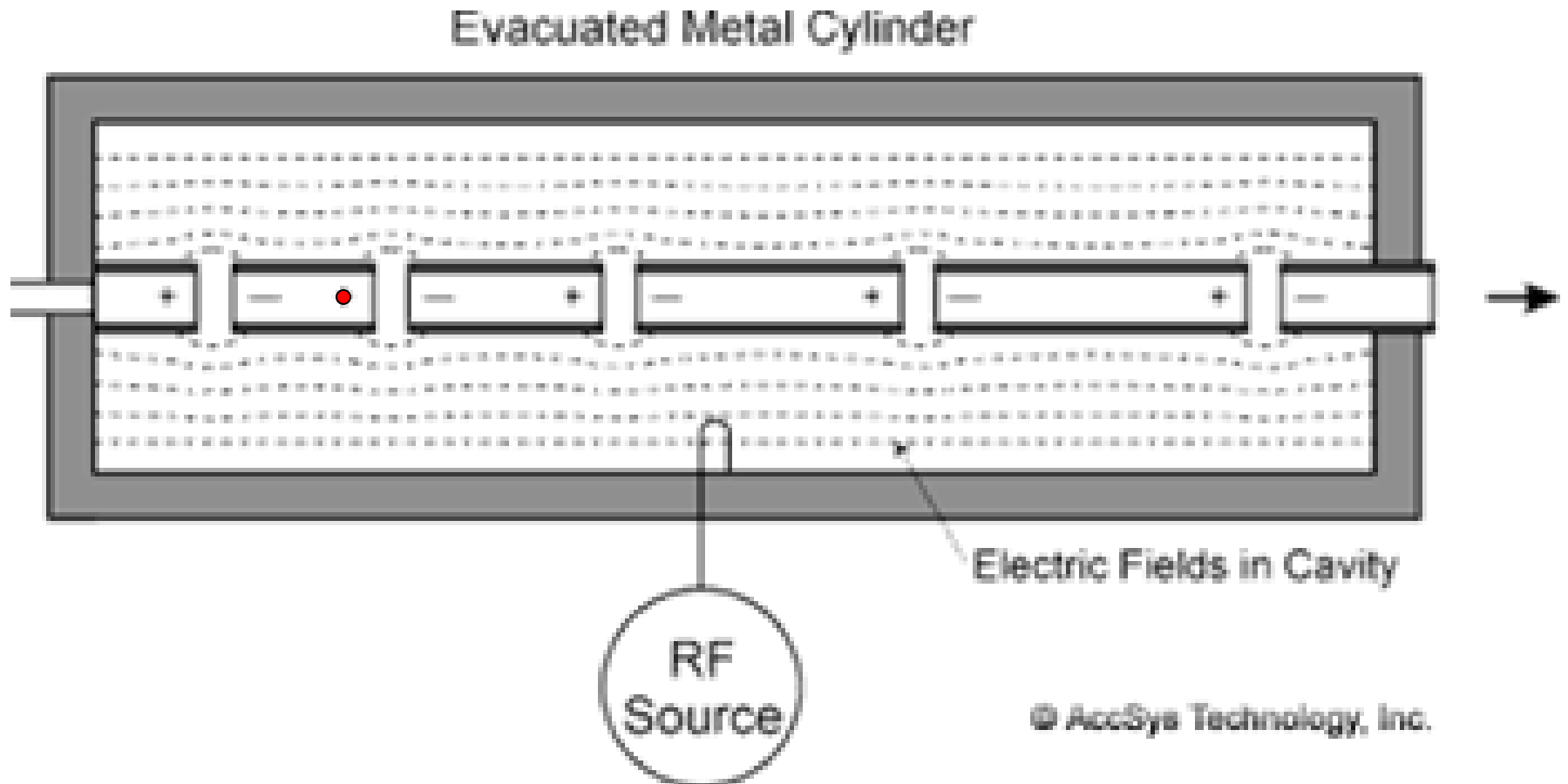



Zero-mode excitation of a Drift Tube Linac Tank

- $\phi = \omega t = 2\pi$, $E_z = E_0$

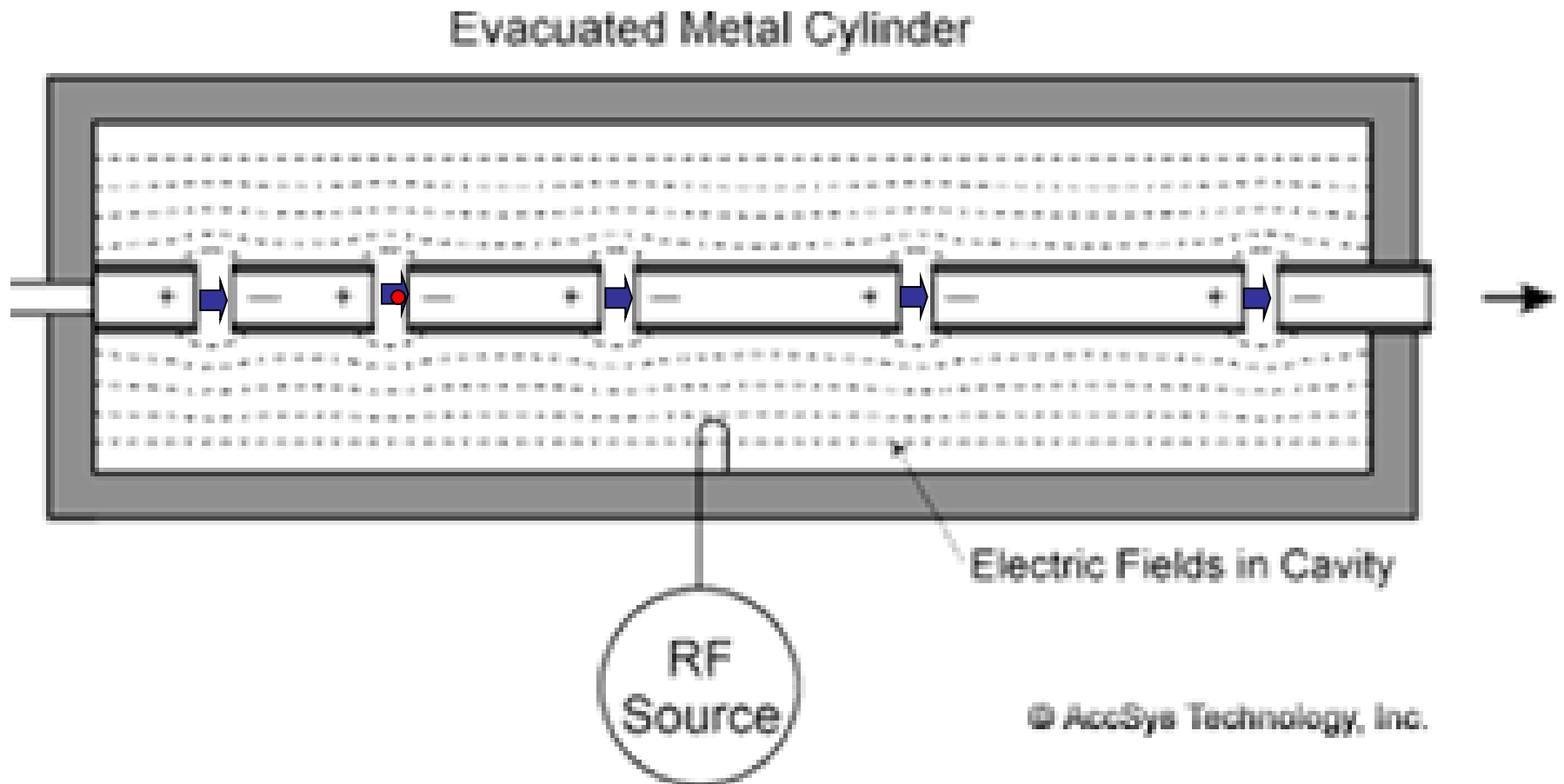



Alvarez Drift Tube Linac

- DTLs are used to accelerate protons from ~ 1 MeV to ~ 100 MeV.
- At higher energies, the drift tubes become long and unwieldy.
- DTL frequencies are in the 200-400 MHz range.

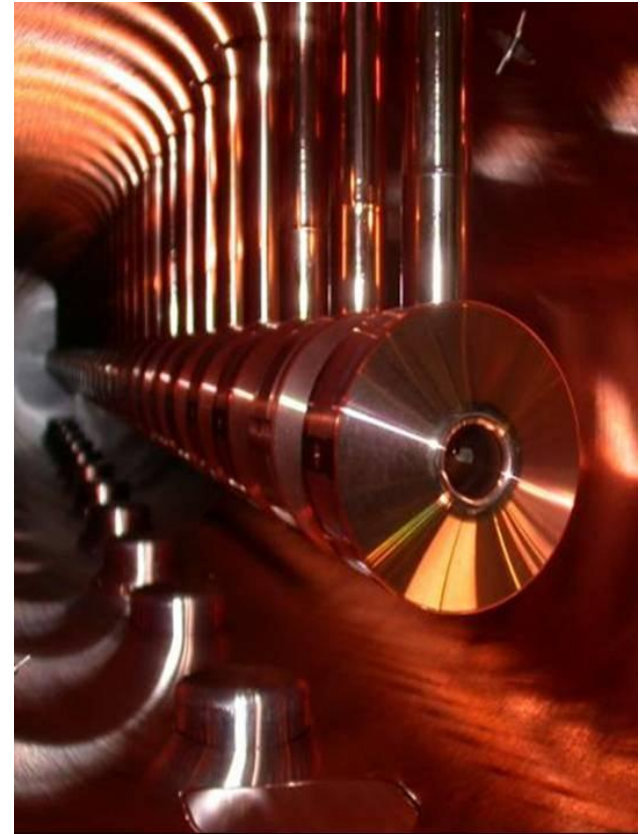



Coupled Cavity Linac

- Long array of coupled cavities driven in $\pi/2$ mode.
- Every other cavity is unpowered in the $\pi/2$ mode.
- These are placed off the beam axis in order to minimize the length of the linac.
- To the beam, the structure looks like a π mode structure.
- Actual CCL structures contain hundreds of coupled cavities, and therefore have hundreds of normal-modes. Only the $\pi/2$ mode is useful for beam acceleration.
- The cell spacing varies with beam velocity, with nominal cell length $\beta\lambda/2$.

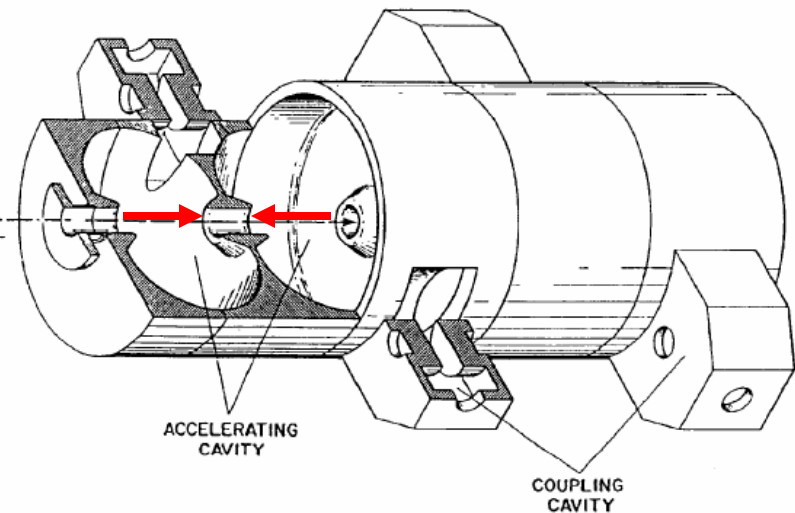



Powering a Linac: Components of a High Power RF System

High Voltage Pulse from a Modulator

RF power is "piped around" in waveguide.

Circulator directs "Reflected Power" away from Klystron, to a load.

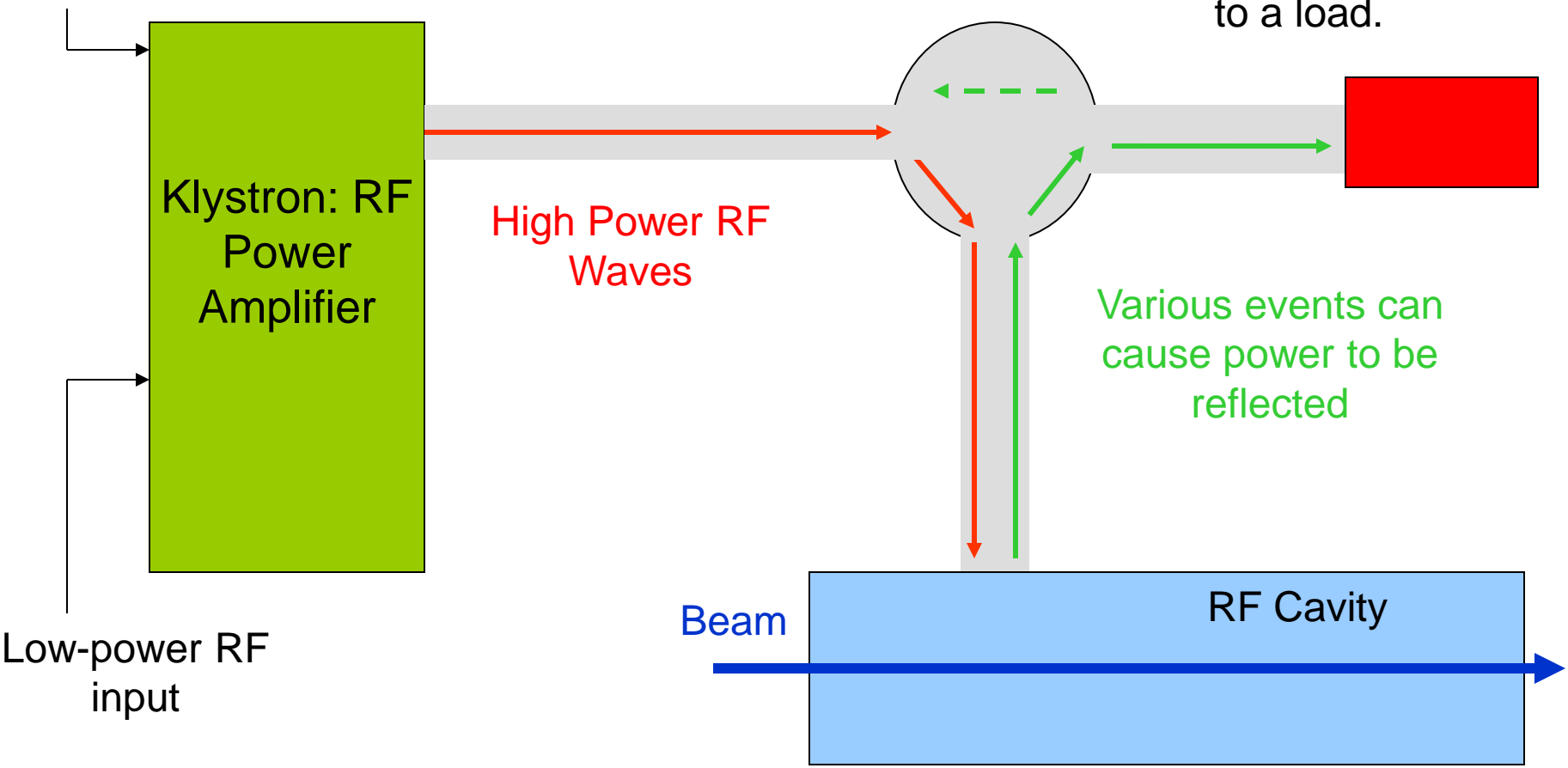



Klystron Operation

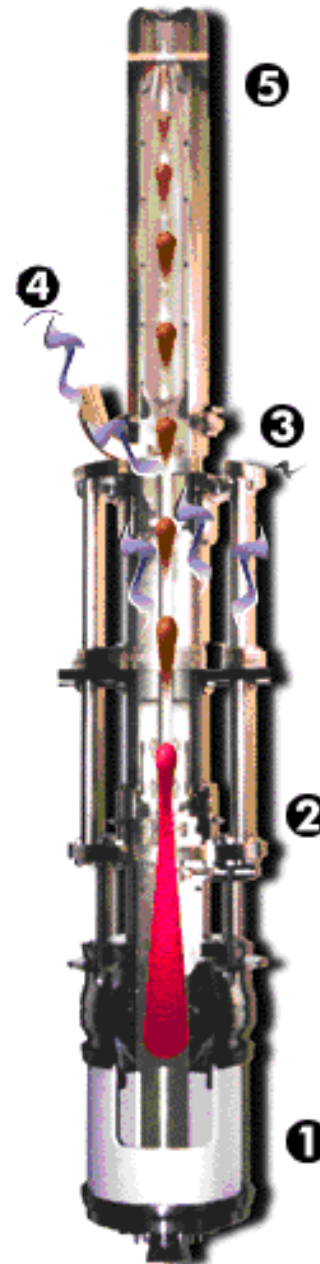
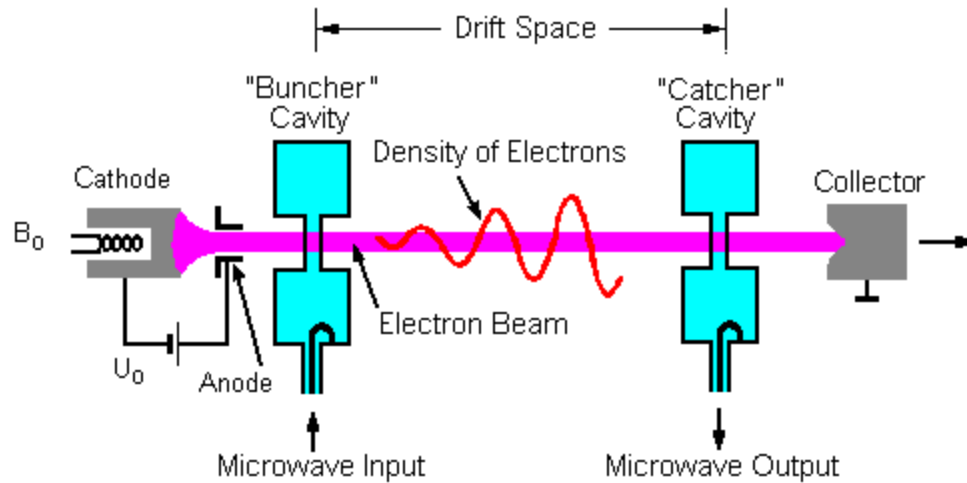

- A Klystron is an amplifier for radio-frequency waves.
- A Klystron is actually a small accelerator/RF cavity system.
- Electrons are produced from a gun.
- A high-voltage pulse accelerates an electron beam.
- Low power RF excites the first cavity, which bunches the electrons.
- These electrons “ring the bell” in the next cavity.
- A train of electron bunches excites the cavity, generating RF power.



Linac RF Systems

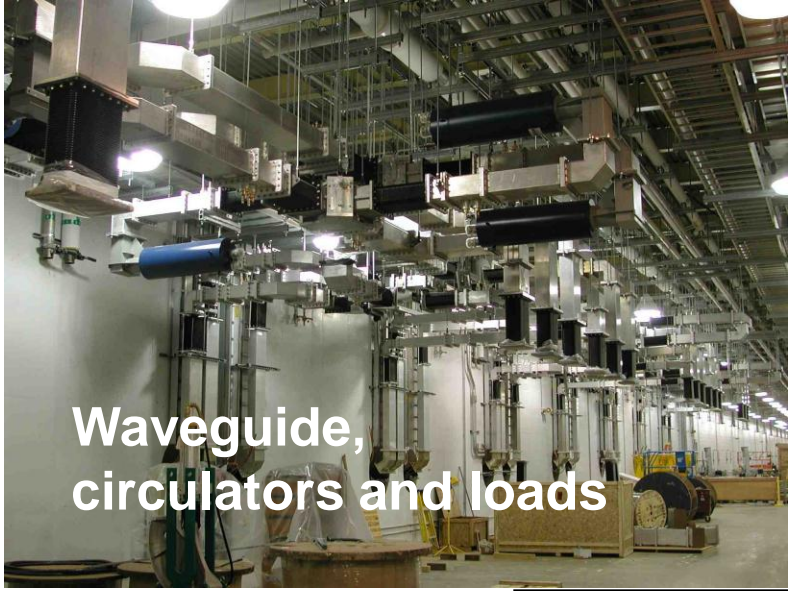

Waveguide, circulators and loads



Klystron Gallery

Cavity Field vs. time without beam

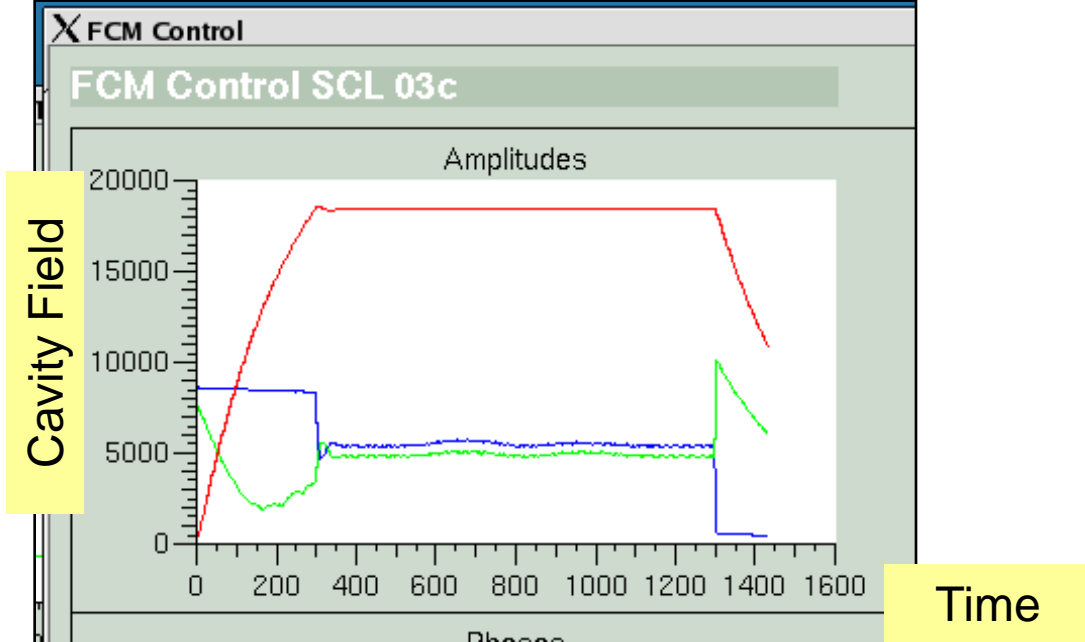



Example Beam Pulse Structure

Macro-pulse

Structure
(made by the
High power
RF)



Mini-pulse

Structure
(made by the
choppers)

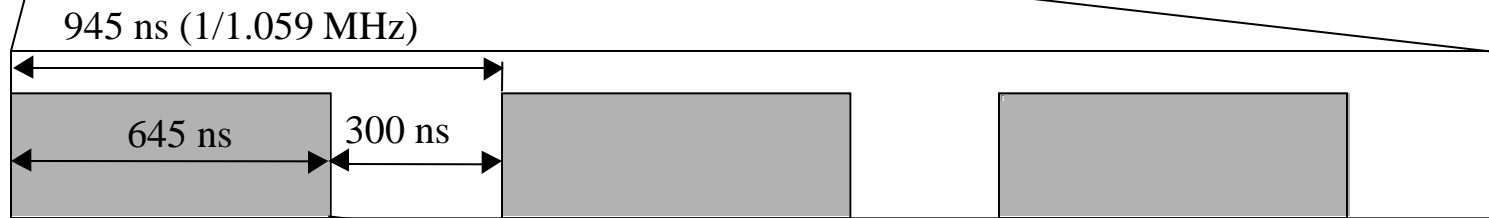

Micro-pulse

structure
(made by the
RFQ)

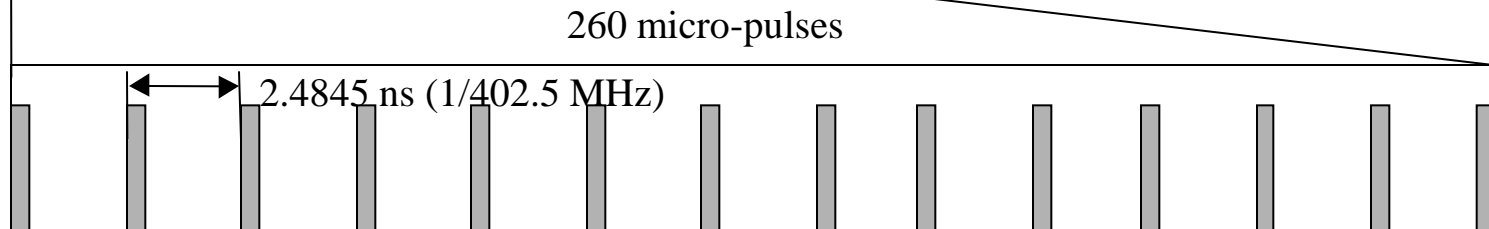



Example Problem

- Consider a 10-cm-long copper ($1/\sigma = 1.7 \times 10^{-8} \Omega \text{ m}$) TM_{010} pillbox cavity with resonant frequency of 500 MHz and axial field $E = 1.5 \text{ MV/m}$.
 - a) For a proton with kinetic energy of 100 MeV, calculate the transit-time factor ignoring the effects of the aperture, and assuming that the velocity remains constant in the gap.
 - b) If the proton arrives at the center of the gap 45 degrees before the crest, what is the energy gain?
 - c) Calculate the RF power dissipated in the cavity walls.
 - d) Suppose this cavity is used to accelerate a 100 mA beam. What is the total RF power that must be provided by the klystron?
 - e) Calculate the shunt impedance, the effective shunt impedance, the shunt impedance per unit length, and the effective shunt impedance per unit length.
 - f) Assume the drift tube bore radius is 2 cm. Calculate the transit-time factor, including the aperture effects, for the proton on-axis, and off-axis by 1 cm. Assume that

$$I_0(x) = 1 + x^2 / 4 \quad J_0(x) = 1 - x^2 / 4$$



Extra Slides



Coupled Cavity Linac Examples

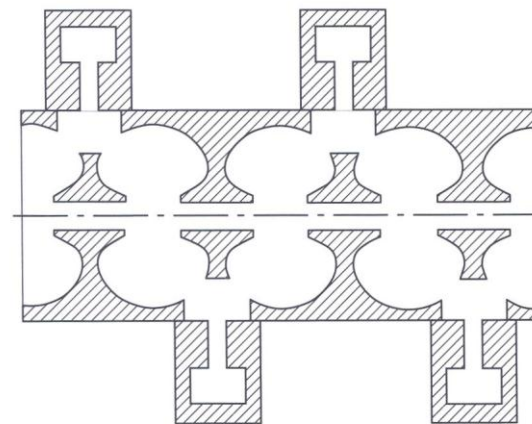
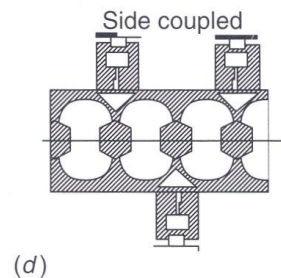
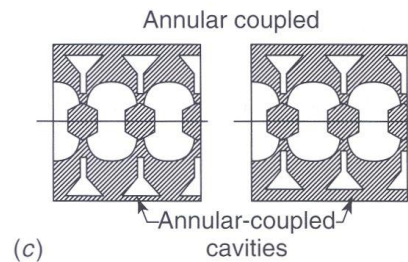
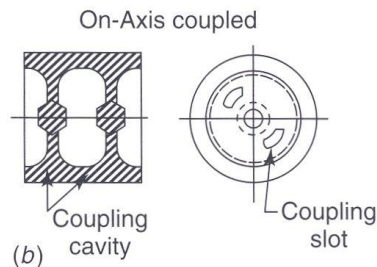
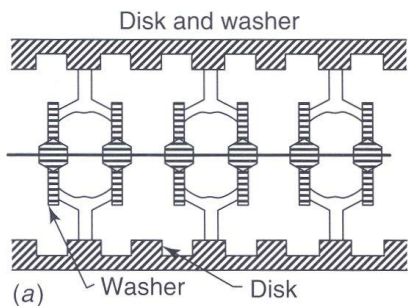
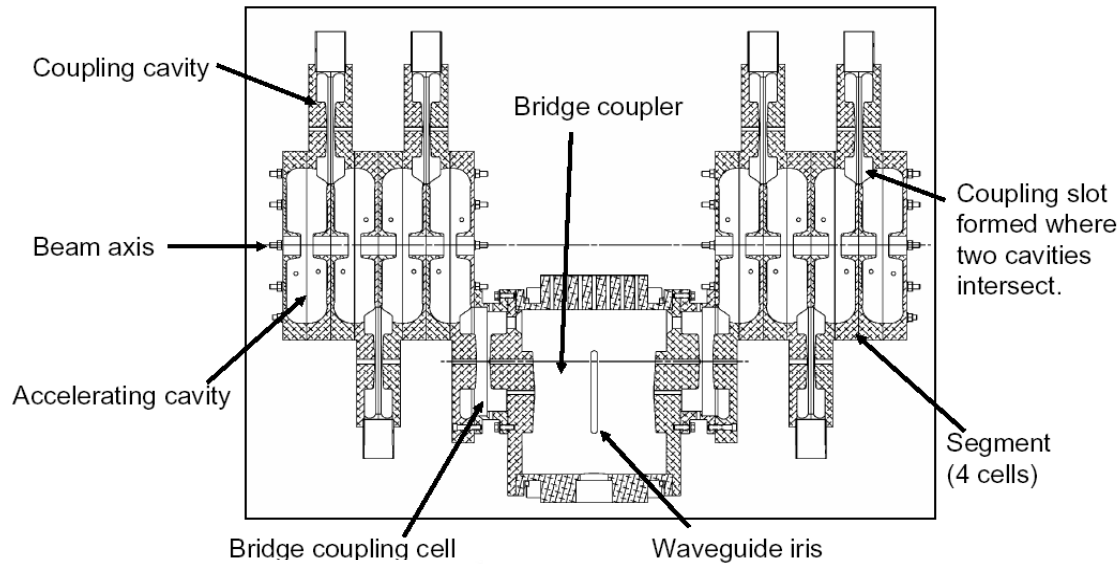

Figure 4.18 Four examples of coupled-cavity linacs are shown as labeled.

Figure 4.12 The side-coupled linac structure as an example of a coupled-cavity linac structure. The cavities on the beam axis are the accelerating cavities. The

cavities on the side are nominally unexcited and stabilize the accelerating-cavity fields against perturbations from fabrication errors and beam loading.



Other Types of RF Structures

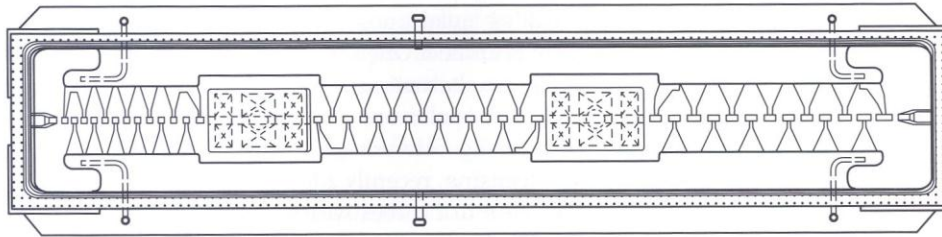

(a)

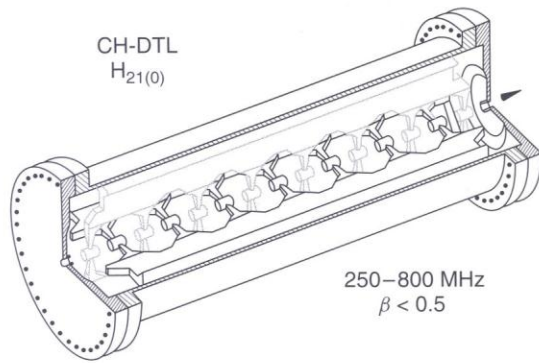

(b)

Figure 4.6 (a) Interdigital H-mode (IH) structure showing regions with a long sequence of electrodes for acceleration with no transverse focusing lenses separated by triplet quadrupoles to provide transverse focusing (courtesy of U. Ratzinger). (b) Crossbar H-Mode or CH structure (courtesy of U. Ratzinger).

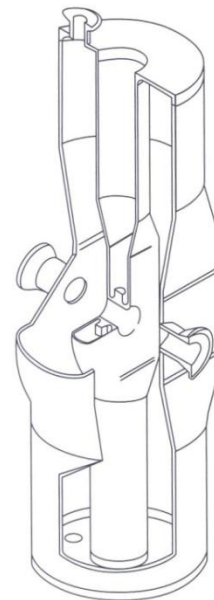

Figure 4.26 350-MHz $\beta = 0.12$ coaxial half-wave resonator with a single loading element (courtesy of J. R. Delayen, Ref. 33).



Other Types of RF Structures

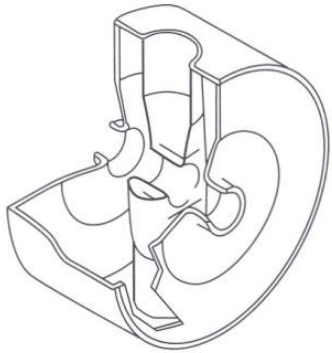
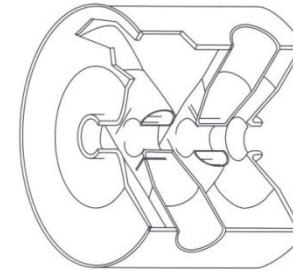
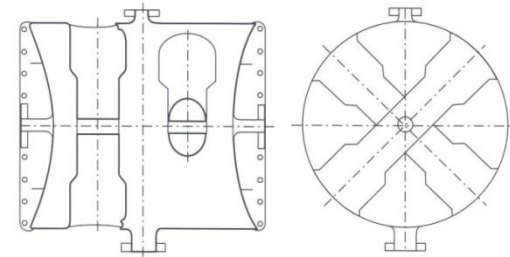

Figure 4.27 850-MHz, $\beta = 0.28$ spoke resonator (courtesy of J. R. Delayen, Ref. 33).



(a)



(b)



(c)

Figure 4.28 Spoke cavities with multiple loading elements. (a) An 850-MHz, $\beta = 0.28$ double spoke concept. (b) A 345-MHz, $\beta = 0.4$ double spoke concept. (c) A 700-MHz, $\beta = 0.2$ eight-spoke concept (courtesy of J. R. Delayen, Ref. 33).